

CAD FILE:

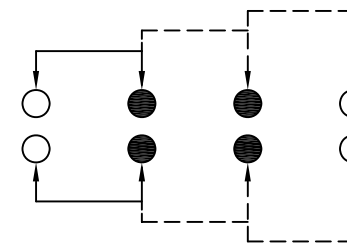

SCHEMATIC (NON-SHORTING)

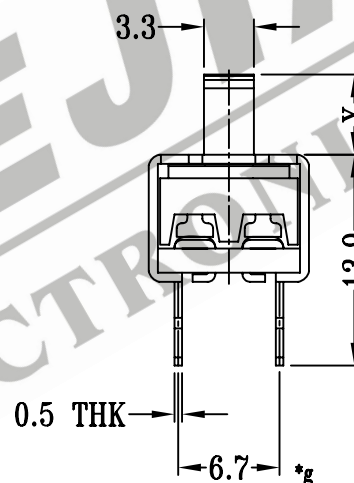
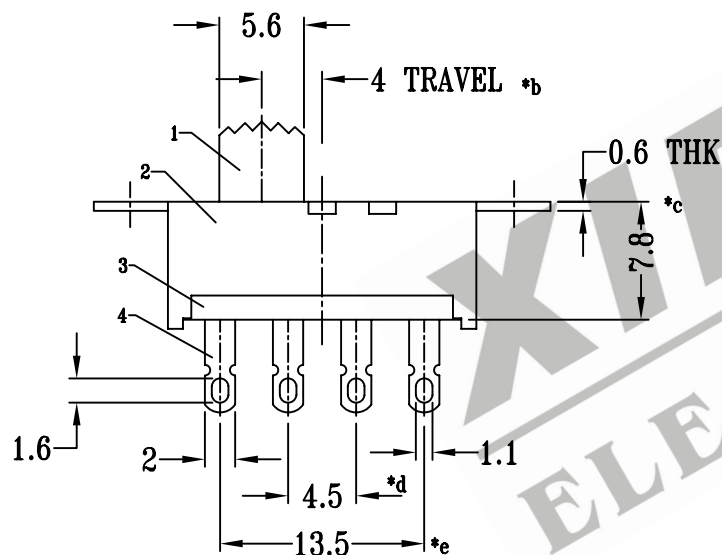
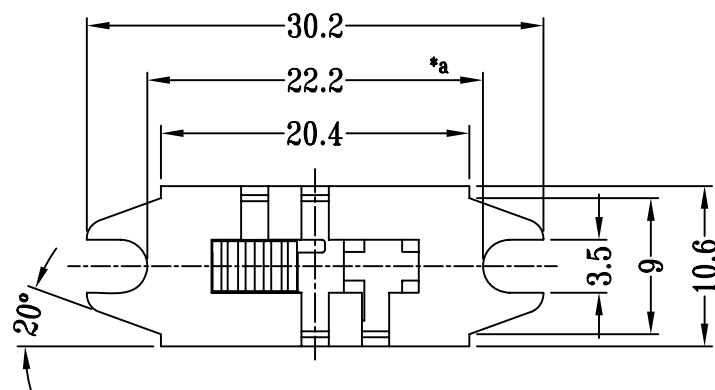
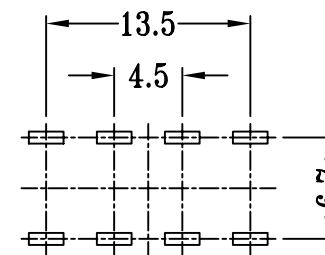

P.C.B LAYOUT

注:带"\*"表示关键尺寸(7个)

NO.	PARTS	MATERIALS	Q'TY	FINISH	TOLERANCE UNLESS SPECIFIED	SHENZHEN XIEJIA ELECTRONICS CO.,LTD.				
8						TITLE : VERTICAL SLIDE SWITCH MODEL: SS-23H26				
7										
6	SPRING PLATE	PBS STRIP	3	NATURAL	WITHIN: 1.5±0.1mm OVER : 1.5±0.2mm	ISSUE	DATE	DESCRIPTIONS OF REV ISION		APPD.
5	CONTACT CLIP	COPPER STRIP	2	Ag PLATED						
4	TERMINAL	COPPER STRIP	8	Ag PLATED OVER Ni PLATED				UNIT : mm		DRWG NO.: XJ-DR-SS23H26-00
3	BASE	PHENOLIC RESIN	1	BLACK				SCALE: 2 : 1		DWN. ZHOUYU 2003-11-21
2	FRAME	STEEL STRIP	1	Zn PLATED						CHK'D FANGYING 2003-11-21
1	KNOB	PC	1	BLACK						APPD. KANGXINAN 2003-11-21
ALL MATERIALS MUST BE COMPLIANT TO ROHS										